

COMPANY PROFILE



PT CARAKA ANUGRAH SANTOSO



PT CARAKA ANUGRAH SANTOSO

ABOUT US

PT Caraka Anugrah Santoso berdiri sejak tahun 2017 di bidang fabrikasi baja dengan komponen terbesarnya masih menggunakan bahan impor untuk memproduksi Head Spun Pile Foundation yang berkualitas. Inilah awal mula PT Caraka Anugrah Santoso memulai untuk menjadi bagian dari pembangunan Indonesia.

Sehubungan dengan tingginya pembangunan di Indonesia, hal ini membuat kami berinisiatif untuk mengembangkan teknologi pembuatan Join Plate agar dapat diproduksi dalam negeri.

Pada awal tahun 2020 PT Caraka Anugrah Santoso memulai pembuatan Joint Plate dengan mendirikan pabrik yang berlokasi di Sadang, Jawa Barat. Pabrik kami menerapkan proses "Hot Rolling Mill" yang didukung dengan menggunakan bahan baku lokal.

Produk Joint Plate yang dibuat oleh PT Caraka Anugrah Santoso merupakan yang pertama di produksi lokal di Indonesia dan menjadi kebanggaan tersendiri sebagai salah satu karya anak bangsa. Produk ini akan digunakan untuk memenuhi kebutuhan pasar dalam negeri maupun luar negeri.

PT Caraka Anugrah Santoso berkomitmen memberikan kepuasan pelanggan dalam hal kualitas produk sesuai dengan standar yang ditetapkan di sertai dengan dukungan purna jual. Dengan beroperasinya PT Caraka Anugrah Santoso diharapkan dapat memberikan dampak positif terhadap kemajuan bangsa dan negara Indonesia.



THE FIRST IN INDONESIA!

PT Caraka Anugrah Santoso was established in 2017 as a steel fabrication unit using imported materials to produce high quality Head Spun Pile Foundation.

Keeping pace with the ambitious infrastructure development projects undertaken by the Government of Indonesia, we took the initiative to develop the technology for indigenous production of Join Plates and thus substitute imports.

In early 2020 PT Caraka Anugrah Santoso started the manufacture of Joint Plate by establishing a factory located in Sadang, West Java. Ours is the first factory in Indonesia to introduce the hot-rolling process for production of joint plates.

PT Caraka Anugrah Santoso is committed to providing customer satisfaction in terms of product quality in accordance with established standards along with efficient after-sales support. With the operation of PT Caraka Anugrah Santoso, it is hoped that it will have a positive contribution to the progress of the Indonesian economy.



OUR VISION AND MISSION

VISI

Menjadi Perusahaan Industri baja, Produksi Joint Plate yang terbaik, dan mampu bersaing untuk Pasar Lokal dan Pasar International.

VISION

To be a producer of the best quality Joint Plate, and be able to compete in the local market and the international market.

MISI

- Menghasilkan produk Joint Plate yang berkualitas dan berstandar Internasional.
- Memberikan pelayanan yang profesional demi tercapainya kepuasan pelanggan.
- Melaksanakan operasi yang efisien dengan tetap menjaga keselamatan kerja, kesejahteraan karyawan dan lingkungan yang baik.

MISSION

- *Produce high quality Joint Plates matching to the best international standards.*
- *Provide professional services to achieve customer satisfaction.*
- *Carry out efficient operations while maintaining work safety, employee welfare and a good environment.*

OUR CORE VALUES

1

EXCELLENCE

2

COMMITMENT

3

TEAM WORK

4

PROFESSIONALISM

5

SUSTAINABILITY

6

RELIABILITY

7

PASSION





OUR PRODUCT

Joint Plate dibuat khusus untuk bagian ujung atau tengah Spun Pile dengan diameter 300 mm sampai dengan 1200 mm. Sedangkan untuk aplikasinya Spun Pile digunakan untuk pondasi tiang pancang.

Joint Plate is specially made for head or middle of Spun Pile with diameter 300 mm to 1200 mm. As for the application Spun Pile is used for foundation piles.

Joint plate population

- diameter 300
- diameter 350
- diameter 400
- diameter 450
- diameter 500
- diameter 600
- diameter 800
- diameter 1000
- diameter 1200

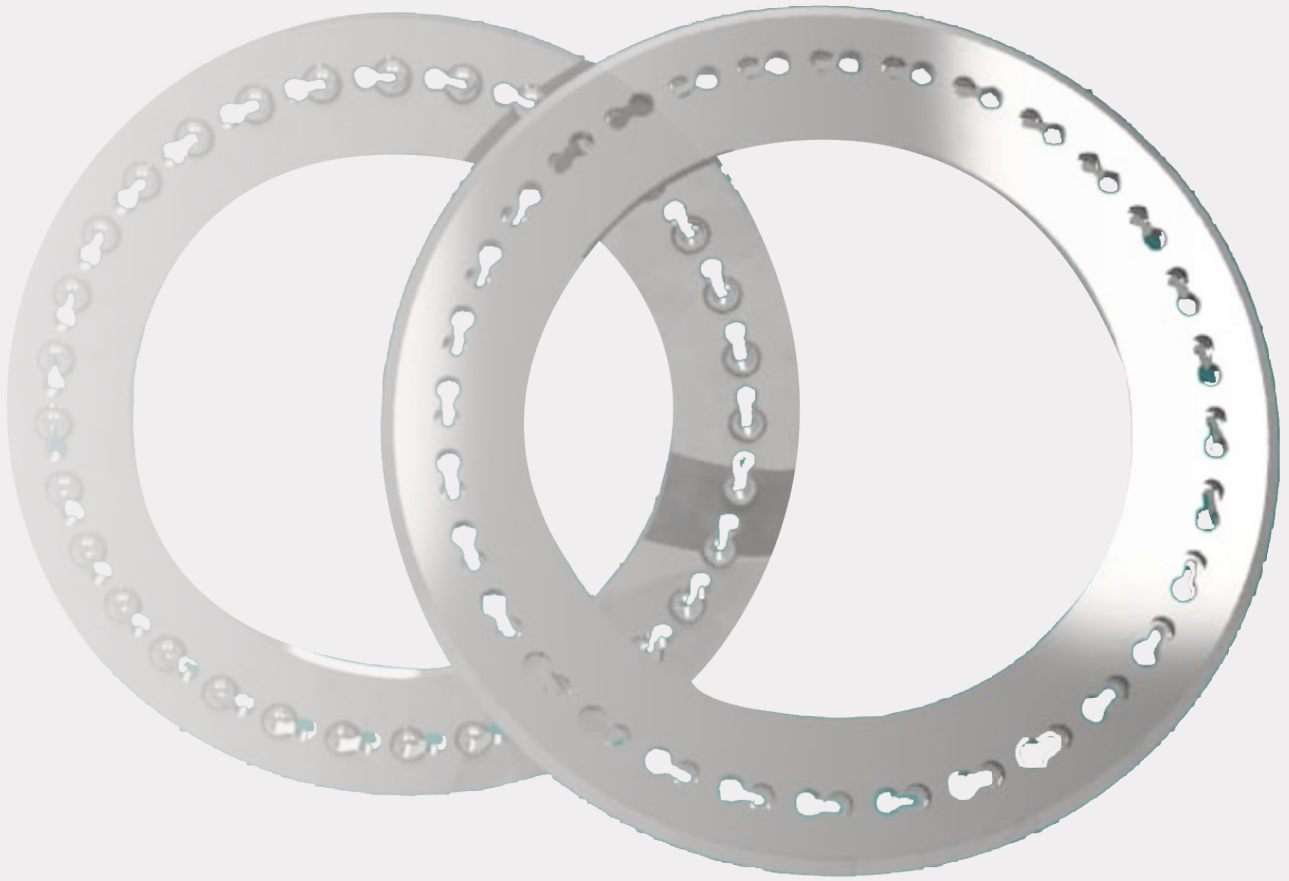

JOINT PLATE

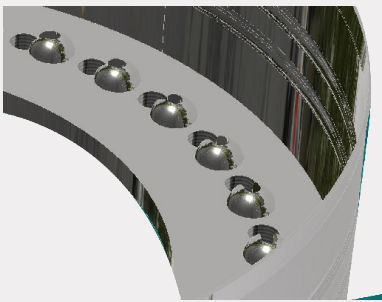

**HIGH QUALITY
NOTCHING**

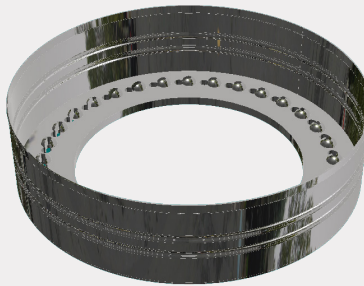

**HIGH
PRECISION
THREAD**

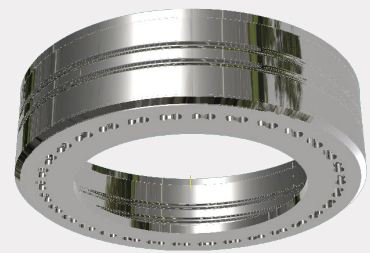

**DESIGN PRODUCT
QUALITY**

SHAPE DIMENSION

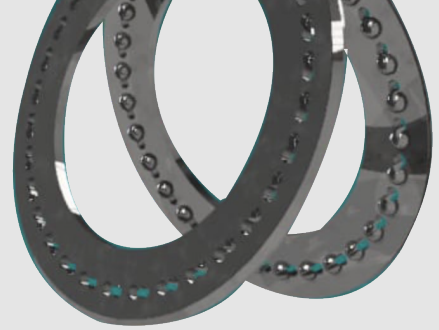

PRODUCT SIZE

No	Outer Diameter (mm)		Inner Diameter (mm)	Width (mm)	Thickness (mm)
	D	D1	D3	W	T
1	300	298	180	60	12
					16
2	300	298	160	70	16
					18
3	350	348	220	65	12
					16
4	400	398	250	75	12
					16
5	400	398	210	95	16
					18
					20
6	450	448	290	80	12
					16
7	500	498	320	90	12
					16
8	500	498	300	100	18
					20
					24
9	500	498	250	125	18
					20
					24
10	600	598	400	100	12
					16
11	600	598	380	110	18
					20
					24
12	600	598	340	130	18
					20
					24
13	700	698	480	110	20
14	700	698	440	130	24
15	800	798	580	110	20
16	800	798	540	130	24
17	800	798	560	120	16
					19
					22
					25
18	1000	998	740	130	28
19	1000	998	720	140	19
					22
					25
20	1200	1198	900	150	30
21	1200	1198	900	150	19
					22
					25

SPECIFICATION REQUIREMENT

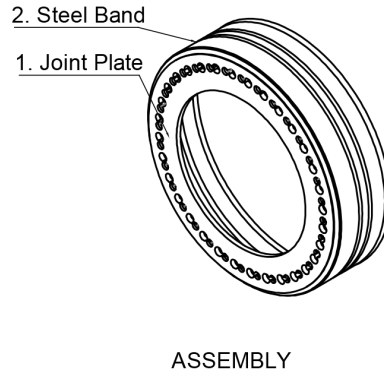
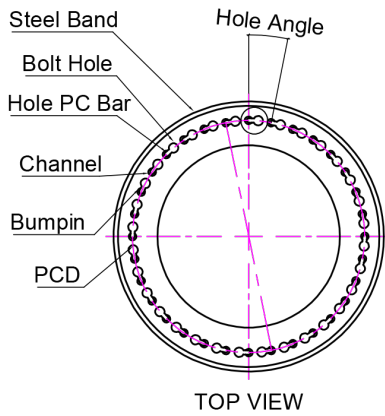

1. Joint Plate

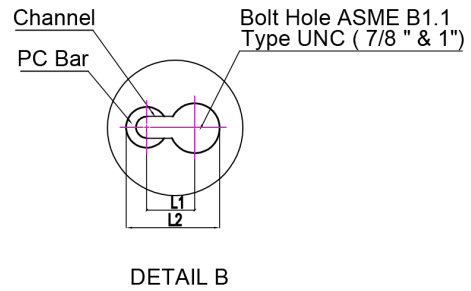
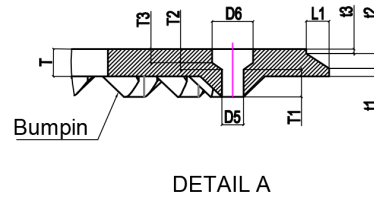
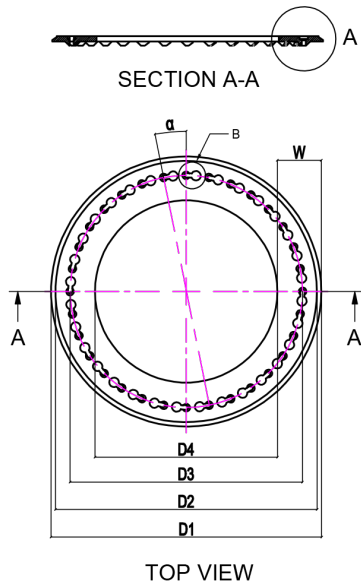

2. Steel Band

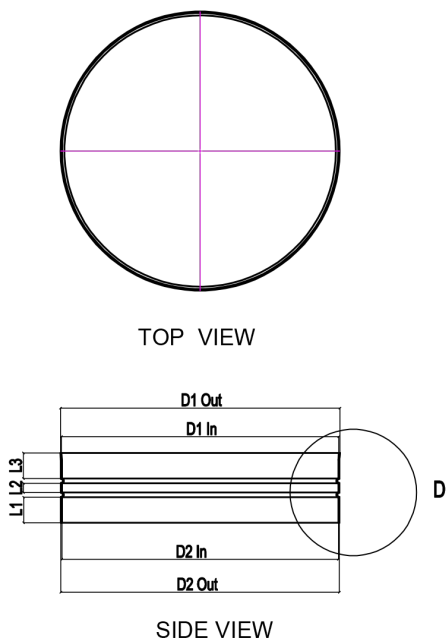

PROCESS PRODUCTION

Proses produksi dilakukan secara terintegrasi dengan didukung oleh peralatan dan teknologi mutakhir. Pemeriksaan kualitas yang ketat dilakukan pada setiap tahap produksi.

Production process is carried out in an integrated manner backed by state-of-the-art equipment and technology. Stringent quality checks are done at every stage of production.



PROCESS PRODUCTION

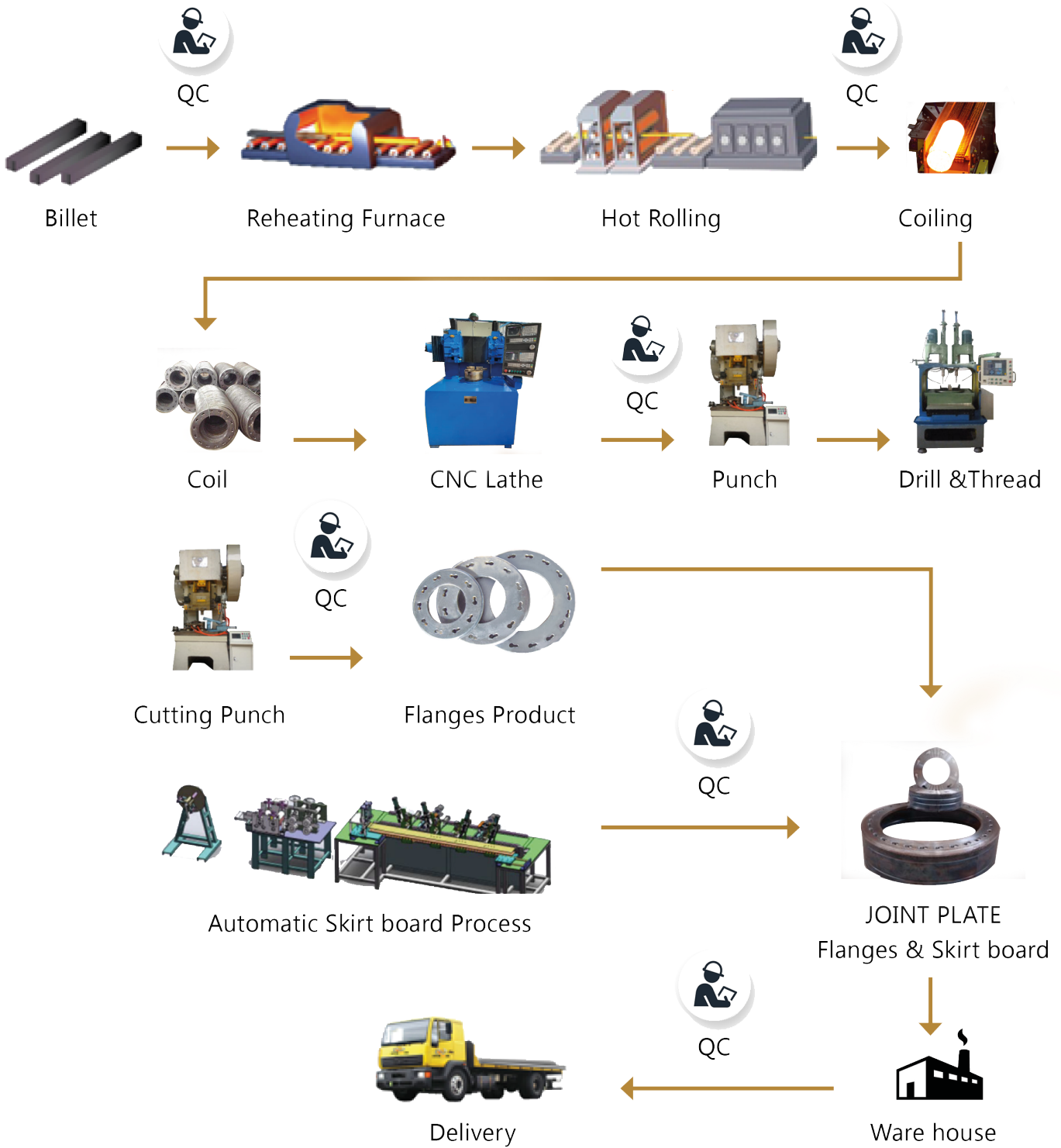



PT CARAKA ANUGRAH SANTOSO

Head Office & Factory:

JL. Raya Sadang Subang
KM 18 No.11
Cipinang. Kec Cibatu.
Kab Purwakarta
Jawa Barat 41181
(0264) 839119

Marketing

Representative Office:

Rukan Sentraniaga
Blok RSN 3 No.007
Jaka Setia, Bekasi Selatan
Kota Bekasi 17147
(021) 82732817

www.carakasteel.com